



COMBINATION PICNIC TABLE - BENCH

Model 97736

ASSEMBLY & SET-UP INSTRUCTIONS



Diagrams within this manual may not be drawn proportionally.

Due to continuing improvements, actual product may differ slightly from the product described herein.

Distributed exclusively by Harbor Freight Tools®.

3491 Mission Oaks Blvd., Camarillo, CA 93011

Visit our website at: <http://www.harborfreight.com>



**Read this material before using this product.
Failure to do so can result in serious injury.
SAVE THIS MANUAL.**

Copyright© 2008 by Harbor Freight Tools®. All rights reserved. No portion of this manual or any artwork contained herein may be reproduced in any shape or form without the express written consent of Harbor Freight Tools.

For technical questions or replacement parts, please call 1-800-444-3353.

SAVE THIS MANUAL

Keep this manual for the safety warnings and precautions, assembly, operating, inspection, maintenance and cleaning procedures. Write the product's serial number in the back of the manual near the end of this manual (or month and year of purchase if product has no number). Keep this manual and the receipt in a safe and dry place for future reference.

IMPORTANT SAFETY INSTRUCTIONS

In this manual, on the labeling, and all other information provided with this product:



This is the safety alert symbol. It is used to alert you to potential personal injury hazards. Obey all safety messages that follow this symbol to avoid possible injury or death.

DANGER

DANGER indicates a hazardous situation which, if not avoided, will result in death or serious injury.

WARNING

WARNING indicates a hazardous situation which, if not avoided, could result in death or serious injury.

CAUTION

CAUTION, used with the safety alert symbol, indicates a hazardous situation which, if not avoided, could result in minor or moderate injury.

NOTICE

NOTICE is used to address practices not related to personal injury.

CAUTION

CAUTION, without the safety alert symbol, is used to address practices not related to personal injury.

READ AND UNDERSTAND ALL INSTRUCTIONS

When using this product, safety precautions should always be followed including the following:

General Safety

1. Do not use this product for other than its intended use. Inspect before use. Do not use if parts are loose or damaged.
2. Maintain labels and nameplates on the product. These carry important safety information. If unreadable or missing, contact Harbor Freight Tools for a replacement.
3. This product is not a toy. Keep it out of reach of children when children are not being closely supervised.
4. Make sure to install this product on a clean, dry, flat, level surface capable of supporting the weight of the product and its contents.
5.  Wear ANSI-approved safety impact goggles and heavy-duty work gloves when assembling this product.
6. Do not exceed the total weight capacity of **(400 pounds)**. Also, make sure the weight is distributed evenly on each Bench. Be aware of dynamic loading. Dropping or bouncing on bench may briefly create excess load causing product failure.

7. Never allow people or animals to stand or climb on this product.
8. Pinch point warning: Use caution to avoid pinching fingers when assembling and setting up this unit.
9. Adults only should perform the assembly and set-up of this product.
10. When in use, make sure all Legs of the product are flat on the ground.
11. The warnings, precautions, and instructions discussed in this instruction manual cannot cover all possible conditions and situations that may occur. It must be understood by the operator that common sense and caution are factors which cannot be built into this product, but must be supplied by the operator.



SAVE THESE INSTRUCTIONS.

SPECIFICATIONS

Construction Material	Unfinished Fir Yellow/Green Zinc Plated Steel Bolts, Washers, Nuts, and Screws
Weight Capacity	400 Pounds Total (Distributed Evenly)
Umbrella Hole Diameter	1-5/8"
Waterproof Water Resistant	No

UNPACKING

When unpacking, check to make sure that the item is intact and undamaged. If any parts are missing or broken, please call Harbor Freight Tools at the number shown on the cover of this manual as soon as possible.

ASSEMBLY

Note: For additional information regarding the parts listed in the following pages, refer to the accompanying illustrations.

1. Attach the two Folding Beams (2) *flush* to the inner side of the Table Top (5), using six Bolts each with two Washers and one Nut (9). **(See Figure A.)**
2. **NOTE:** The Bolts and Washers (9) should be inserted from the *outside* of the Table Top (5) into the Folding Beams (2). **(See Figure A.)**

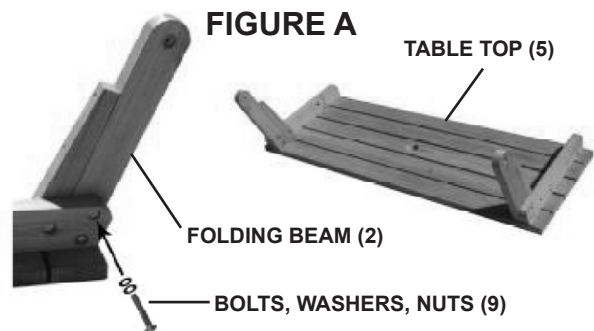

3. Place and align the Short Bench Top (8) flush on the two Bench Supports (4). **(See Figure B.)**
4. Fasten the eight Screws (11) into the pre-drilled holes on the Short Bench Top (8) to the Bench Supports (4). **(See Figure B.)**

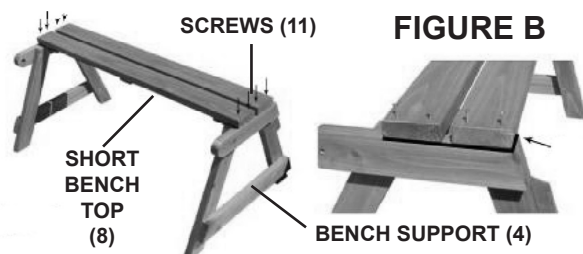

- Turn the assembled Bench upside down.
- Position the Diagonal Supports (7) so one end is against the longer cross beam of Bench Support (4) legs. Then align the other end so it is *flush to the wood edge* next to the center gap of the Short Bench Top (8). The two Diagonal Supports (7) need to be attached at opposite sides of the bench gap, using three Screws (11) per Support. (i.e., one support will be attached to one bench slat, and the other bench slat will be attached to the other bench support. (See Figure C.)

- NOTE:** There are no pre-drilled holes for the Screws (11) in the bench slat or Bench Supports (4). Instead, there are guide marks in the wood to indicate where the Screws must be inserted. (See Figure C.)

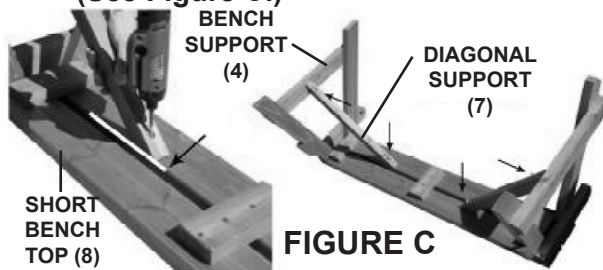

FIGURE C

- Set the Table on its side.
- Attach the Folding Beams (2) to the outside edge of the Bench Supports (4), using two Bolts, each with four Washers, and one Nut (10). (See Figure D.)

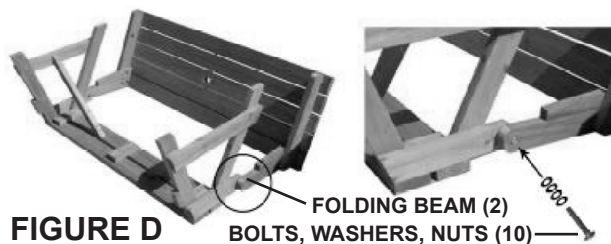

FIGURE D

FOLDING BEAM (2)
BOLTS, WASHERS, NUTS (10)

- Hold the Table securely in its standing position.
- Attach the two Table Legs (1) to the Table Top (5) by inserting two Bolts each, with four Washers and one Nut (10) into the pre-drilled hole at the rounded end of the Table Legs. **NOTE:** One pre-drilled hole still remains below the Table Legs. (See Figure E.)

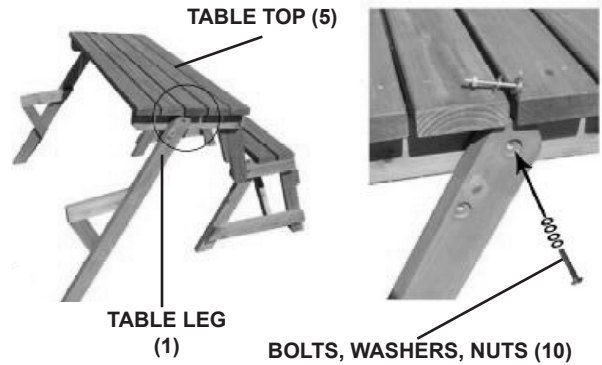

FIGURE E

- Attach the two Arm Rests (3) to the Table Legs (1), using two Bolts, each with four Washers and one Nut (10). (See Figure F.)

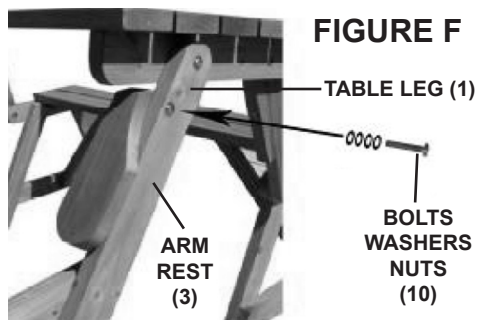

FIGURE F

- Place the Long Bench Top (6) on the Table Legs (1). Make sure the longer bar underneath the Long Bench top is toward the *outside*. (See Figure G.)
- Fasten the eight Screws (11) into the pre-drilled holes in the Long Bench Top (6) to the Table Legs (1). (See Figure G.)

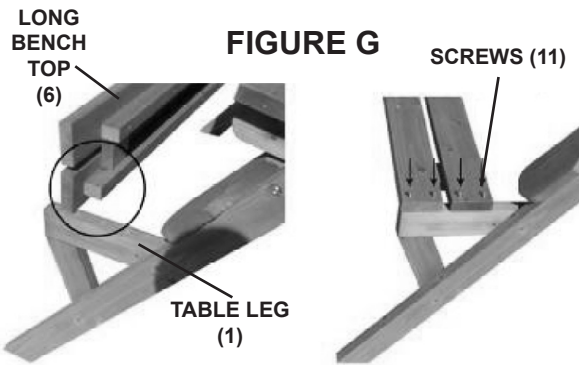

FIGURE G

15. To transform the Picnic Table into a Bench, simply lift up the Table Top (5) and Arm Rests (3).
(See Figures H, I, and J.)



FIGURE H



FIGURE I



FIGURE J

16. **IMPORTANT:** To extend the life of this Picnic Table/Bench, it is recommended that you thoroughly coat it with an appropriate protectant (i.e., paint, varnish, etc.).

INSPECTION AND MAINTENANCE

1. **PERIODICALLY**, inspect the general condition of the Picnic Table/Bench. Check for loose connections, improper weight distribution, and any other condition that may affect the product's operation.
2. **TO CLEAN**, use a damp cloth with a mild detergent. Then dry. Do not use solvents.

PLEASE READ THE FOLLOWING CAREFULLY

THE MANUFACTURER AND/OR DISTRIBUTOR HAS PROVIDED THE PARTS LIST AND ASSEMBLY DIAGRAM IN THIS MANUAL AS A REFERENCE TOOL ONLY. NEITHER THE MANUFACTURER OR DISTRIBUTOR MAKES ANY REPRESENTATION OR WARRANTY OF ANY KIND TO THE BUYER THAT HE OR SHE IS QUALIFIED TO MAKE ANY REPAIRS TO THE PRODUCT, OR THAT HE OR SHE IS QUALIFIED TO REPLACE ANY PARTS OF THE PRODUCT. IN FACT, THE MANUFACTURER AND/OR DISTRIBUTOR EXPRESSLY STATES THAT ALL REPAIRS AND PARTS REPLACEMENTS SHOULD BE UNDERTAKEN BY CERTIFIED AND LICENSED TECHNICIANS, AND NOT BY THE BUYER. THE BUYER ASSUMES ALL RISK AND LIABILITY ARISING OUT OF HIS OR HER REPAIRS TO THE ORIGINAL PRODUCT OR REPLACEMENT PARTS THERETO, OR ARISING OUT OF HIS OR HER INSTALLATION OF REPLACEMENT PARTS THERETO.

PARTS LIST & ASSEMBLY DIAGRAM

Part #	Description	Qty.	Part #	Description	Qty.
1	Table Leg	2	7	Diagonal Support	2
2	Folding Beam	2	8	Short Bench Top	1
3	Arm Rest	2	9	Bolt w/Two Washers & One Nut	6
4	Bench Support	2	10	Bolt w/Four Washers & One Nut	6
5	Table Top	1	11	Screw	22
6	Long Bench Top	1			

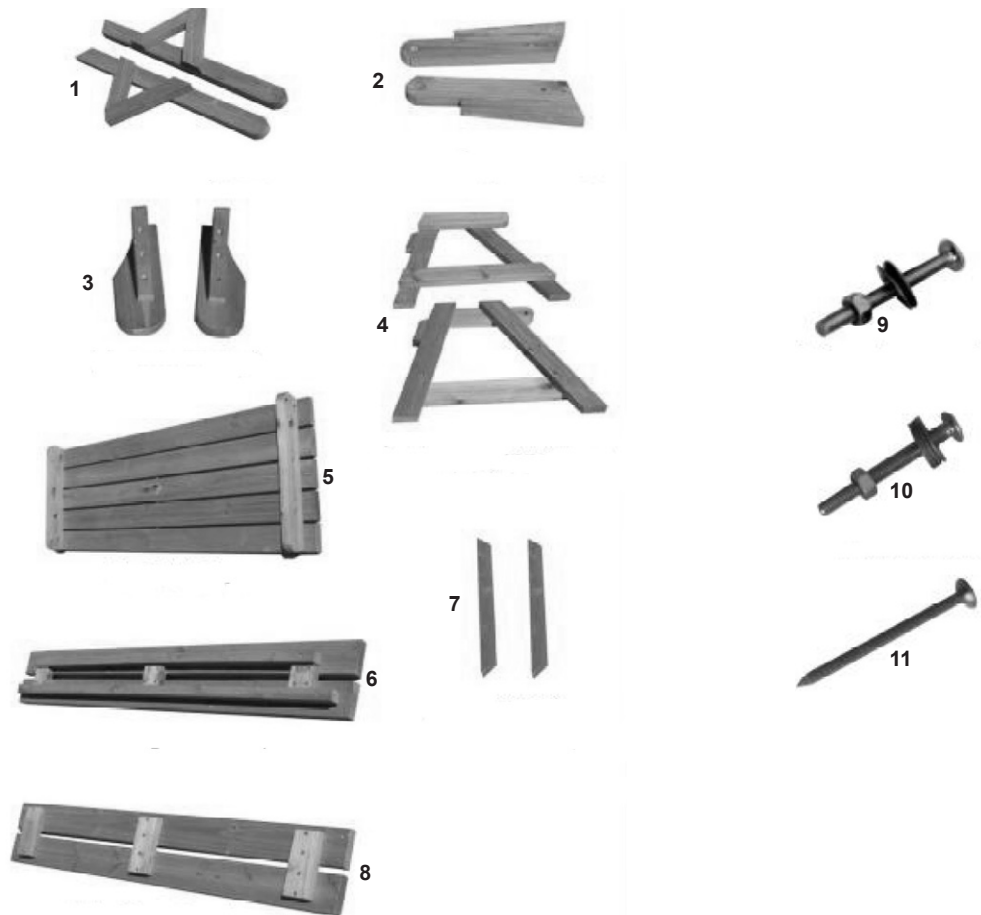

LIMITED 90 DAY WARRANTY

Harbor Freight Tools Co. makes every effort to assure that its products meet high quality and durability standards, and warrants to the original purchaser that this product is free from defects in materials and workmanship for the period of 90 days from the date of purchase. This warranty does not apply to damage due directly or indirectly, to misuse, abuse, negligence or accidents, repairs or alterations outside our facilities, criminal activity, improper installation, normal wear and tear, or to lack of maintenance. We shall in no event be liable for death, injuries to persons or property, or for incidental, contingent, special or consequential damages arising from the use of our product. Some states do not allow the exclusion or limitation of incidental or consequential damages, so the above limitation of exclusion may not apply to you. THIS WARRANTY IS EXPRESSLY IN LIEU OF ALL OTHER WARRANTIES, EXPRESS OR IMPLIED, INCLUDING THE WARRANTIES OF MERCHANTABILITY AND FITNESS.

To take advantage of this warranty, the product or part must be returned to us with transportation charges prepaid. Proof of purchase date and an explanation of the complaint must accompany the merchandise. If our inspection verifies the defect, we will either repair or replace the product at our election or we may elect to refund the purchase price if we cannot readily and quickly provide you with a replacement. We will return repaired products at our expense, but if we determine there is no defect, or that the defect resulted from causes not within the scope of our warranty, then you must bear the cost of returning the product.

This warranty gives you specific legal rights and you may also have other rights which vary from state to state.

3491 Mission Oaks Blvd. • PO Box 6009 • Camarillo, CA 93011 • (800) 444-3353

Record Product's Serial Number Here: _____

Note: If product has no serial number, record month and year of purchase instead.

Note: Some parts are listed and shown for illustration purposes only, and are not available individually as replacement parts.